



Larry Wolff, AIA • George M. Wiens, AIA • Robert J. Hensley, AIA • James P. DiCamillo, AIA  
Glenn Ueda, AIA • Max Medina, AIA • Kelley Needham, AIA • Kevin A. MacQuarrie, AIA

---

February 19, 2010

## **MEETING MINUTES**

### **Franklin Elementary School Modernization**

Project 0913700.01

### **Jackson Elementary School Modernization**

Project 0913800.01

Pasadena Unified School District

District Master Agreement Number: T-090615/0015T

**MEETING DATE:** February 10, 2010

### **ATTENDEES:**

Steve Brinkman, Chief of Facilities, Pasadena Unified School District

Rick M. Byrd, SE, President, R.M. Byrd and Associates, Inc.

Rick McHenry, FCSI, CFSP, Design/Project Management, Laschober & Sovich

Tony Ramirez, President, DCGA Engineers, Inc.

Keith A. Williams, Principal, DCGA Engineers, Inc.

Glenn Ueda, Architect, AIA, Principal, WLC Architects, Inc.

Konni Wong, LEED™ AP, Project Manager, WLC Architects, Inc.

### **PURPOSE OF MEETING**

The purpose of the meeting is to have a kick-off meeting with the consultants and the District at WLC's Office. (See attached Meeting Registry)

### **ITEMS DISCUSSED/ACTION ITEMS**

1. Team introduction.
2. The Architect distributed the Kick-Off Meeting Agenda, Project Team Distribution List, the Preliminary Consultant Schedule, Scope Summary, and 11 x 17 drawings sets. (See attached).

Meeting Minutes

**Franklin Elementary School Addition and Modernization**

Project 0913700.01

**Jackson Elementary School Addition and Modernization**

Project 0913800.01

Pasadena Unified School District

February 19, 2010

Page 2

3. The Architect presented the schematic design and color options to the team and provided the option selected by the design committee. (See attached color renderings)

**ACTION ITEM**

**District**

1. District to determine if they or the A/E Team will perform the electrical panel replacement work.
2. District to send kitchen e-mail reminder on schedule and middle school template to all Architects.
3. District to explore integrating Williams work into modernizations for ceiling work.
4. District to meet with Wes Howard, Debra Amos, and Laschober and Sovich to finalize kitchen layouts.
5. District to question about need/size of grease interceptors.
6. District needs to get Energy Conservation Measures (ECM) list for summer 2010 to Architects.
7. District needs to get most recent Fire Marshal inspection for Jackson to Tony.
8. District to meet with TMAD to understand basis/scope of work.
9. District to get a link to Mechanical Engineer to allow him to access list of priorities.

**Architect**

1. Architect to schedule a meeting with DSA to review and discuss the accessibility issues and concerns for the modernization projects. The Electrical Engineer should participate as fire alarm scope will be defined.

Meeting Minutes

**Franklin Elementary School Addition and Modernization**

Project 0913700.01

**Jackson Elementary School Addition and Modernization**

Project 0913800.01

Pasadena Unified School District

February 19, 2010

Page 3

2. Architect to specify Claridge tackable wall systems.
3. Due to extent of underslab kitchen work, Architect shall plan on removing and replacing concrete floor slab.
4. Architect to provide quarry tile in kitchen and all adjoining spaces.

**Structural Engineer**

1. As-builts requested from Architect for each campus in pdf format.
2. Structural Engineer identified existing concrete wall at Jackson Administration requires Architectural consideration, cannot be removed.
3. Structural Engineer suggested that the existing columns in the Cafeteria which are problematic in their current location may be a candidate for removal. Architect will need to consider new columns against the wall in a furred out cavity. New columns may move toward the kitchen, near the edge of the window, so as to occur in the concrete wall space and not in front of the window. District liked the idea; the estimated cost to remove was \$30,000.00.
4. Structural Engineer needs new mechanical scope for each campus prior to being able to submit proposal for services.

**Mechanical/Plumbing Engineer**

1. The following items pertain to the Franklin Elementary School Modernization project:
  - a. Ductwork to be routed in soffits provided by WLC.
  - b. HVAC equipment shall be replaced in cafeteria and kitchen.
  - c. No hoods will be provided in kitchen per Rick McHenry (Laschober & Sovich).
  - d. Grease interceptor will be required. DCGA to verify with health department.

Meeting Minutes

**Franklin Elementary School Addition and Modernization**

Project 0913700.01

**Jackson Elementary School Addition and Modernization**

Project 0913800.01

Pasadena Unified School District

February 19, 2010

Page 4

- e. All piping in kitchen to be replaced. WLC to demolish existing concrete slab to replace waste lines.
  - f. No fire sprinkler upgrade is required per WLC.
  - g. Exterior drinking fountains to be replaced.
2. The following items pertain to the Jackson Elementary School Modernization project:
- a. Ductwork to be routed in soffits provided by WLC.
  - b. HVAC equipment shall be replaced in kitchen.
  - c. Cafeteria HVAC equipment is fairly new. DCGA to determine if it can be re-used for A/C upgrade.
  - d. Grease interceptor will be required. DCGA to verify with health department.
  - e. All piping in kitchen to be replaced. WLC to demolish existing concrete slab to replace waste lines.
  - f. Steve Brinkman to provide fire sprinkler test results to determine which buildings need fire sprinkler upgrades.
  - g. Exterior drinking fountains to be replaced.
  - h. Building "A" window air conditioners to be replaced. System type to be determined.
  - i. The only fire sprinkler work to be performed shall be that which is required to repair existing installations or work that is now required by code as a condition of approval.

Meeting Minutes

**Franklin Elementary School Addition and Modernization**

Project 0913700.01

**Jackson Elementary School Addition and Modernization**

Project 0913800.01

Pasadena Unified School District

February 19, 2010

Page 5

**Electrical Engineer**

1. The following items pertain to the Franklin ES Modernization project:
  - a. Franklin School panel replacement at Building "C" may not occur. Confirmation from the District is pending. If panels are replaced, fire alarm upgrade will be required.
  - b. DCGA to provide a District 'Standard' for Elementary School Stage Lighting. Simple cost and operation for maximum performance.
2. The following items pertain to the Jackson Elementary School Modernization project:
  - a. Jackson School fire alarm system upgrade may involve adjacent buildings per CSFM findings. WLC to confirm possible impact with DSA.
  - b. DCGA to provide a District 'Standard' for Elementary School Stage lighting. Simple cost and operation for maximum performance.

**Kitchen Consultant**

1. Laschober & Sovich to send schematic design plans of Jackson and Franklin to Steve Brinkman and Debra Amos for their review and approval.

Meeting Minutes

**Franklin Elementary School Addition and Modernization**

Project 0913700.01

**Jackson Elementary School Addition and Modernization**

Project 0913800.01

Pasadena Unified School District

February 19, 2010

Page 6

**NEXT MEETING DATE:** March 10, 2010 at 9:00 a.m.

**END OF MINUTES**

The above represents my best interpretation of the spirit and content of the discussions. Please let me know of any requested modifications or corrections as soon as possible.

Prepared by:



KONNI WONG

Project Manager

LEED™ AP

KW:wq/P00913700x6-mm

Enc.: Meeting Registry  
Kick-Off Meeting Agenda  
Project Team Distribution List  
Preliminary Construction Schedule  
11 x 17 Drawing Sets  
Schematic Design Review Color Renderings

cc: Attendees  
Frazer G. Thompson, PE, LEED AP, Owner Representative, Facilities,  
Pasadena Unified School District  
Gerald Schober, President, SCMC, Inc.  
Ron Canedy, LEED AP, Assistant Vice President - Civil Design, FPL  
and Associates, Inc.  
Carl W. Vail, FCSI, Programming & Concepts, Laschober & Sovich





*Larry Wolff, AIA • George M. Wiens, AIA • Robert J. Hensley, AIA • James P. DiCamillo, AIA  
Glenn Ueda, AIA • Max Medina, AIA • Kelley Needham, AIA • Kevin A. MacQuarrie, AIA*

Kick-off Meeting Agenda  
2-10-10

Franklin Elementary School Modernization (WLC #0913700)  
Jackson Elementary School Modernization (WLC #0913800)

- A. Introductions
- B. Scope of Work - Franklin Elementary School
- C. Scope of Work - Jackson Elementary School
- D. Consultant / Project Schedule Review
- E. Jackson ES Interface With Williams Act Work
- F. Next Meeting
- G. Other

Submitted by,

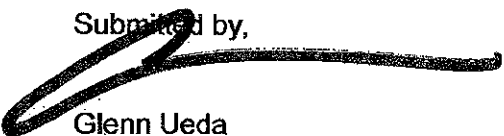

Glenn Ueda  
Architect, AIA  
Principal







Larry Wolff, AIA • George M. Wiens, AIA • Robert J. Hensley, AIA • James P. DiCamillo, AIA  
 Glenn Ueda, AIA • Max Medina, AIA • Kelley Needham, AIA • Kevin A. MacQuarrie, AIA

February 3, 2010

**PRELIMINARY CONSULTANT SCHEDULE**

Franklin Elementary School Modernization  
 Project 0913700.02

Jackson Elementary School Modernization  
 Project 0913800.02

DATE	TIME	PROJECT INFORMATION
February 10, 2010	9:00 a.m. (Wednesday)	Kick off meeting at WLC Architects office. (Architect to distribute backgrounds, soils report, construction document review list).
February 17, 2010	No meeting	Consultant Proposals due at WLC Architects, Inc.
March 3, 2010 10	9:00 a.m. (Wednesday)	Design Development meeting for all disciplines. Finalize all building systems. Start construction documents.
March 24, 2010	No meeting	Consultants post sets of 50% completed drawings to Buzzsaw.
March 31, 2010	9:00 a.m. (Wednesday)	50% final Construction Document review meeting for all disciplines at WLC offices. Provide Architect with itemized cost estimate and catalog cuts of all electrical equipment, light fixtures, and specifications. Civil returns edited specifications. Architect and Owner to verify DSA closeout/certification for previous projects obtained by District.
April 7, 2010	No meeting	Consultants post sets of 80% completed drawings to Buzzsaw.
April 14, 2010	9:00 a.m. (Wednesday)	80% final construction document review meeting for all disciplines.
April 21, 2010	No meeting	Consultants post sets of 100% completed drawings to Buzzsaw.
April 28, 2010	9:00 a.m. (Wednesday)	100% final Construction Document review meeting for all disciplines at WLC offices. Architect to obtain plan check fee from District. (Consultants to turn in construction document review list).
April 28, 2010	No meeting	Consultants submit three (3) sets of Final Construction Documents with license stamps, structural calculations, and completed construction document review.
April 30, 2010	No meeting	DSA plan check submittal.

Submitted by,

KONNI WONG  
 LEED™ AP  
 Project Manager

KW:br/P00913700x2-sch

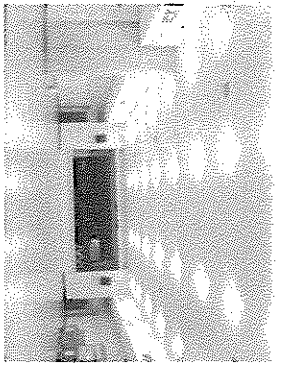

Existing View at Auditorium Platform Area



Proposed Rear Wall at Auditorium



Existing View entry to Auditorium/Cafeteria

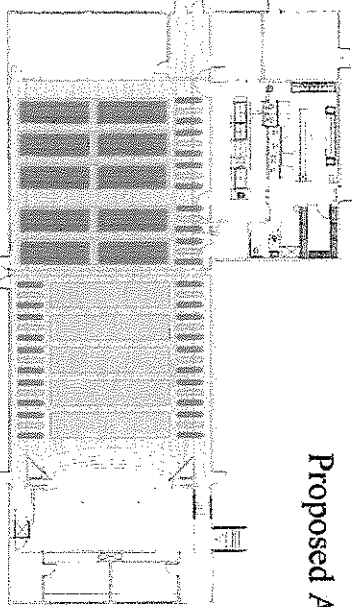

Proposed Floor Pattern & Colors

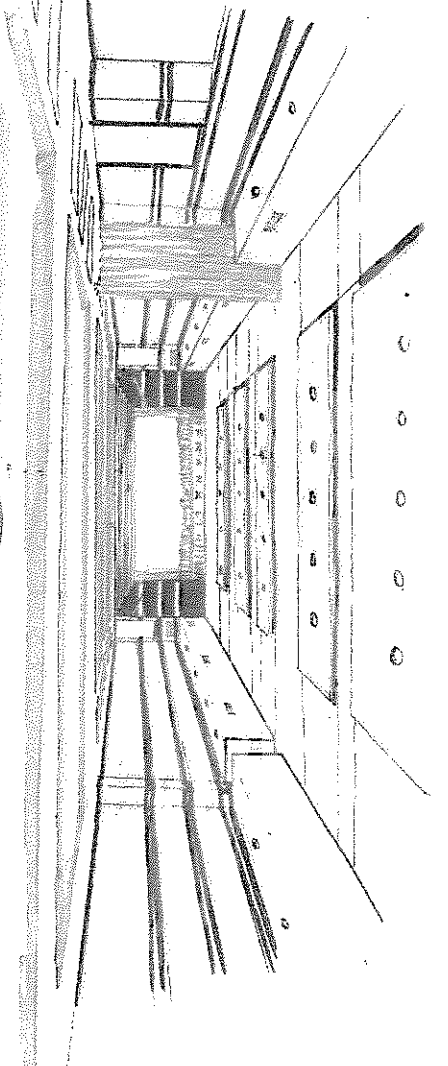

Proposed Auditorium/Cafeteria - Option 1

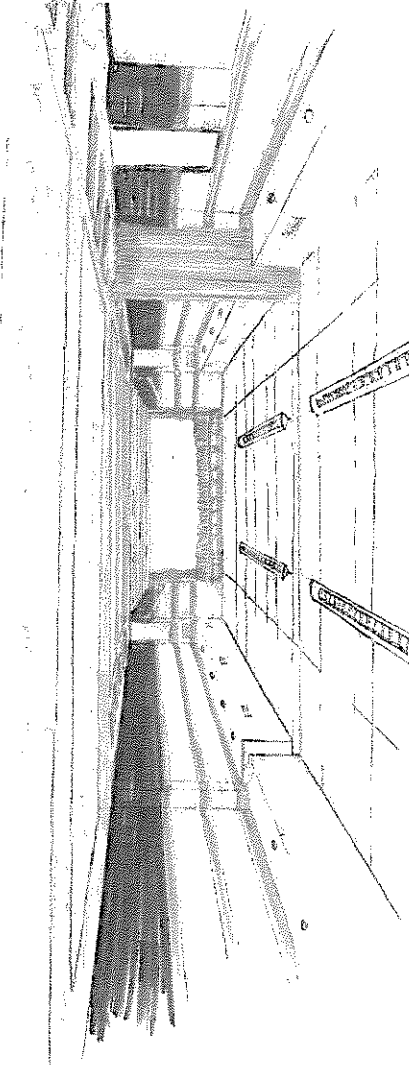

Proposed Auditorium/Cafeteria - Option 2



Existing View at Cafeteria

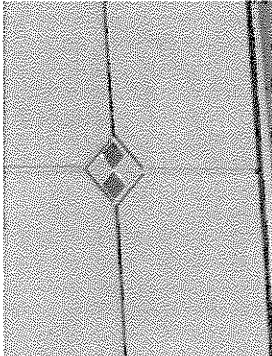

Existing Detail

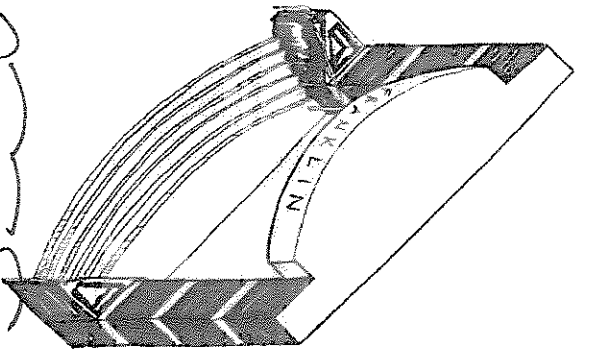

Proposed Platform Area - Option 1

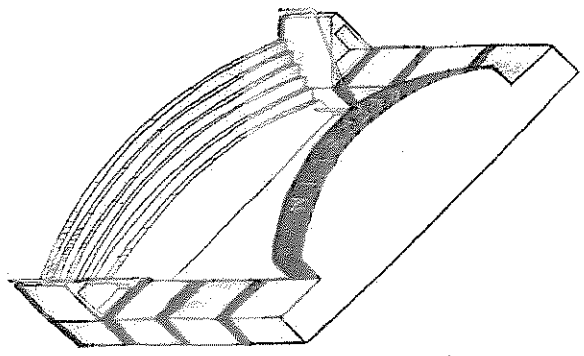

Proposed Platform Area - Option 2

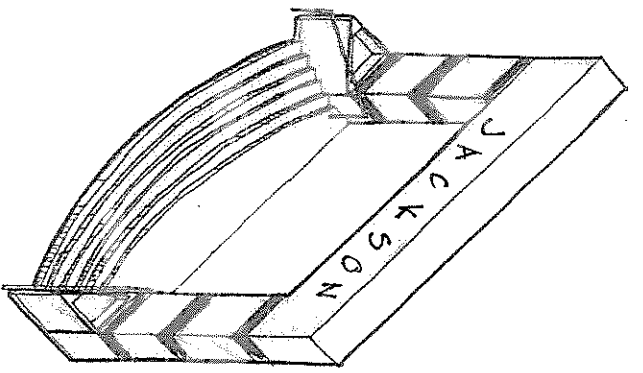

Proposed Platform

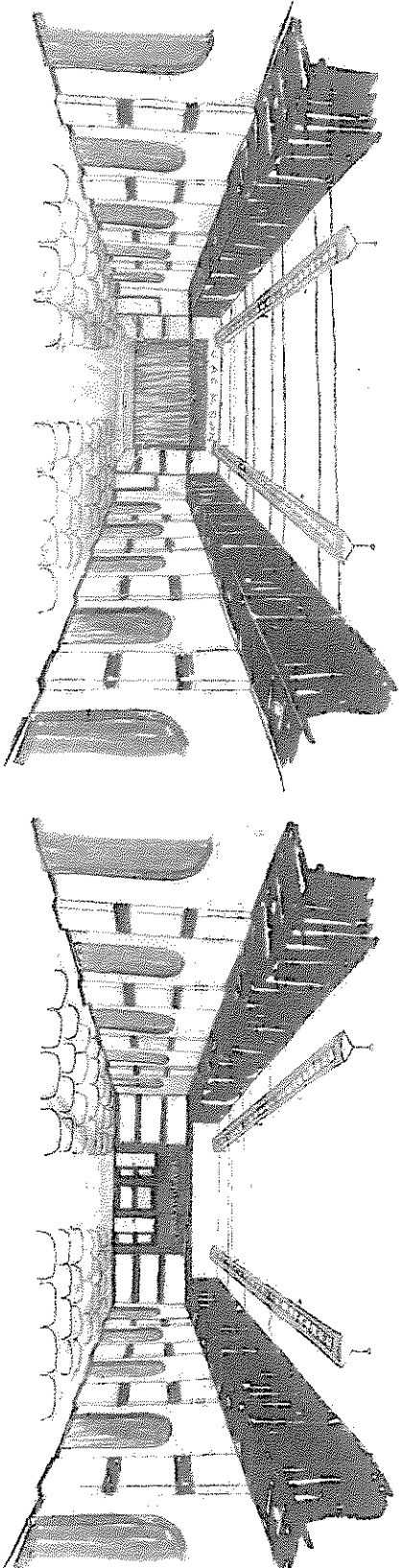

Proposed Auditorium View at Platform Area - Option 1

Proposed Auditorium View at Entry - Option 1

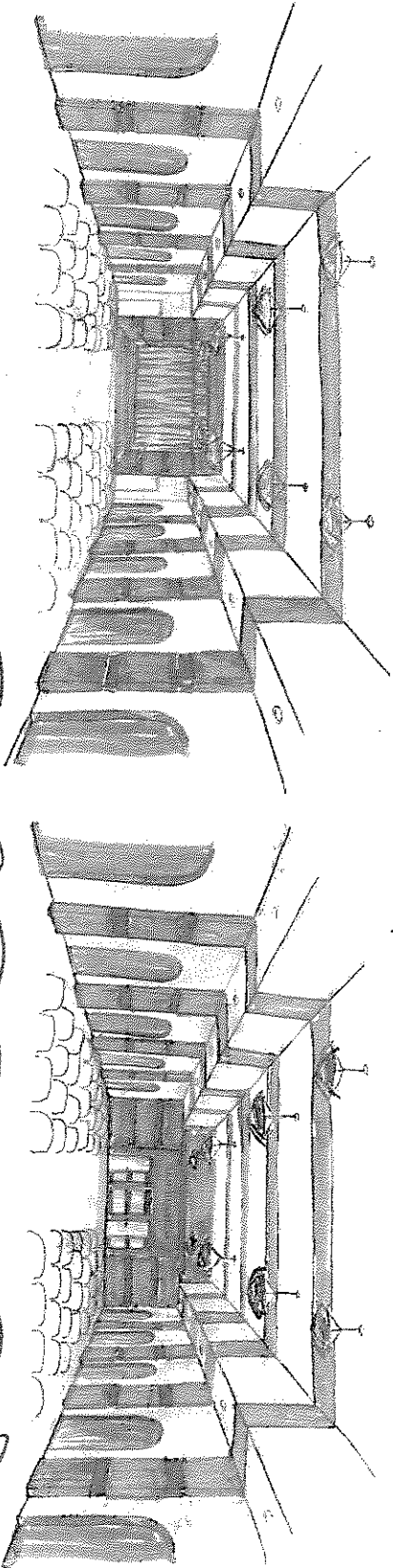

Proposed Auditorium View at Platform Area - Option 2

Proposed Auditorium View at Entry - Option 2

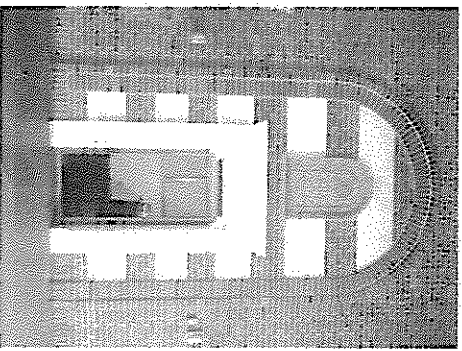

Existing Architectural Style and Character

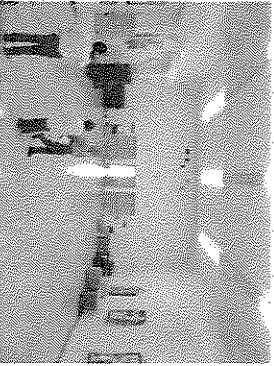

Existing Auditorium - View at Entry

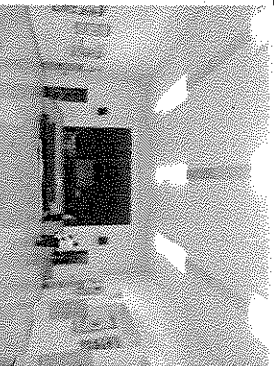

Existing Auditorium - View at Platform Area

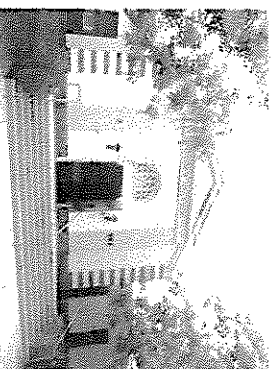

Existing School Entry

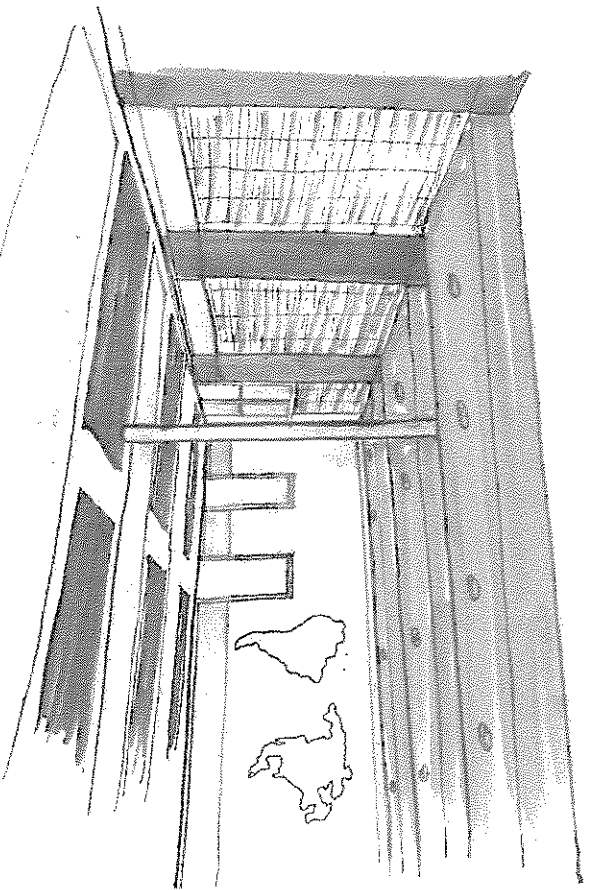

Proposed Cafeteria - Option 1

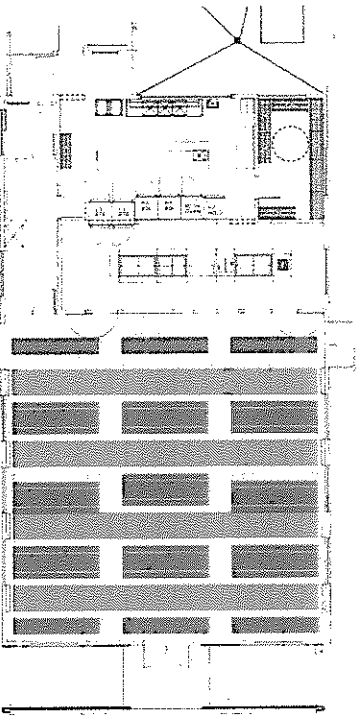

Proposed Floor Pattern & Colors

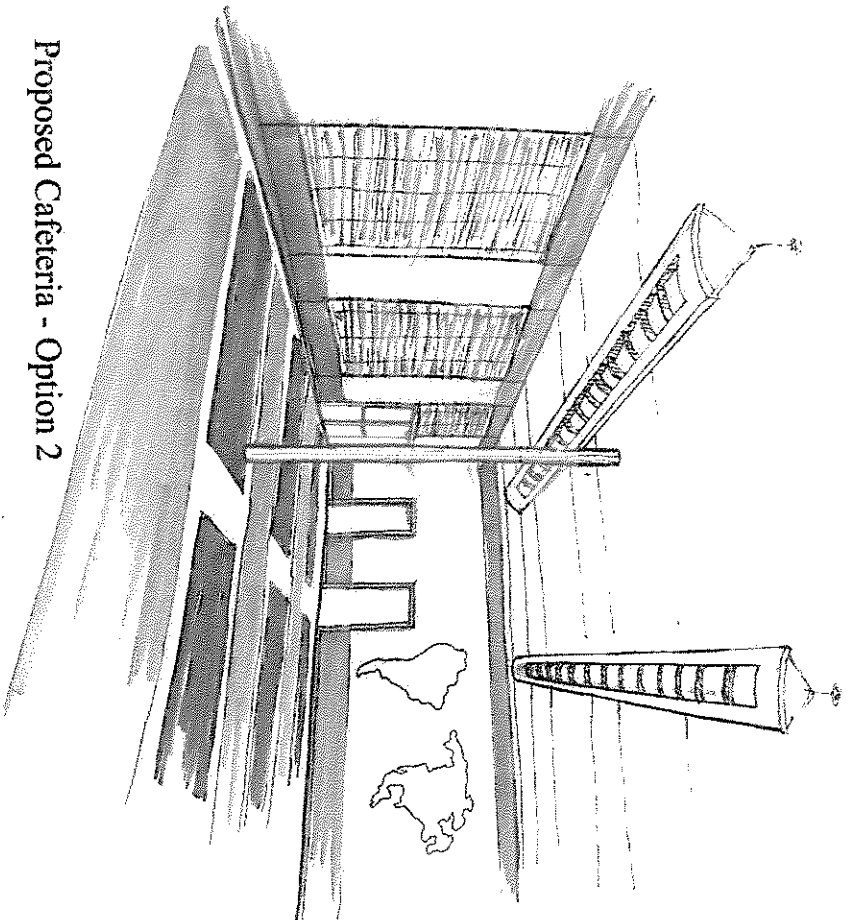

Proposed Cafeteria - Option 2



Existing Cafeteria



Existing Cafeteria

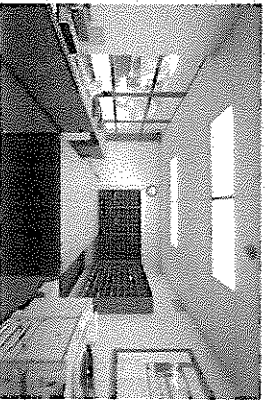
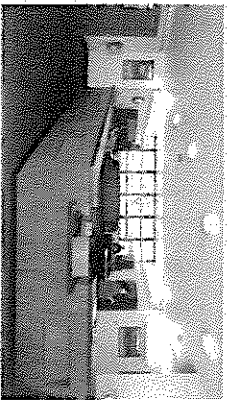
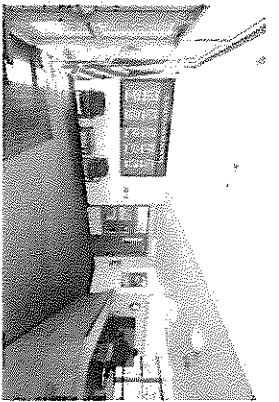

Previously Completed Project For Reference

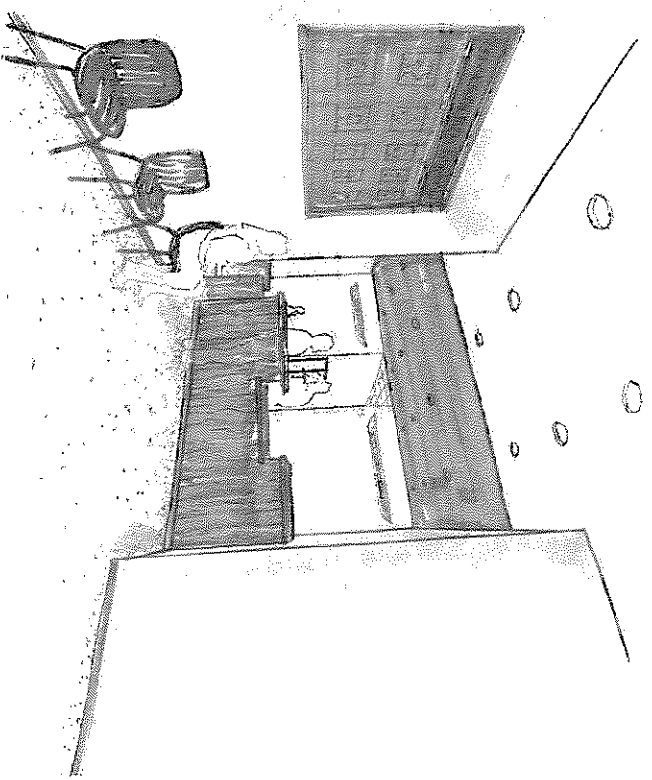

Proposed Reception Area - Option 1

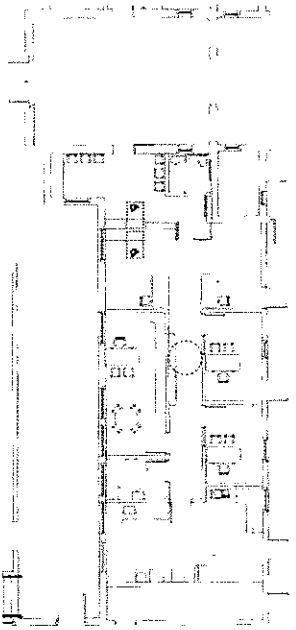

Proposed Floor Plan

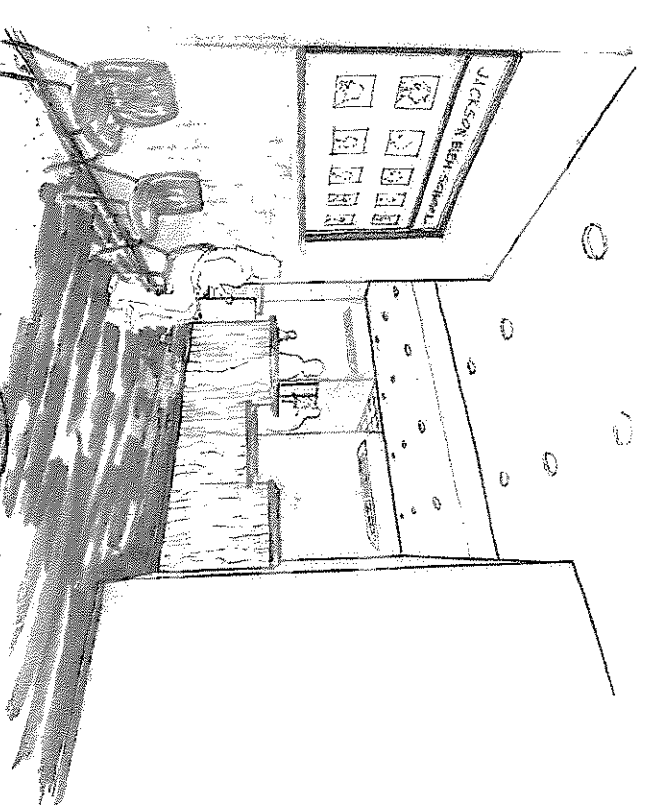

Proposed Reception Area - Option 2

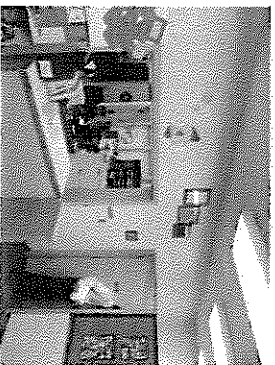

Existing Reception Area



Existing Reception Area



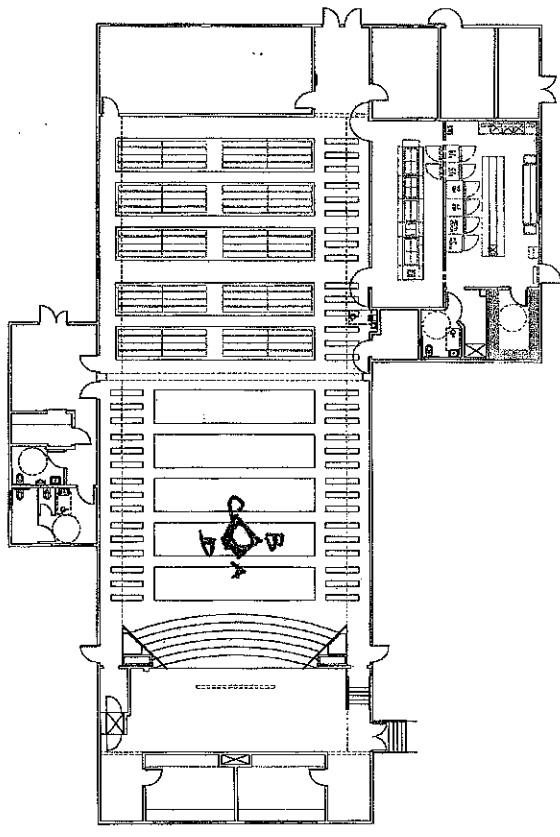

BUILDING H - AUDITORIUM/CAFETERIA/KITCHEN - CONSTRUCTION FLOOR PLAN

SCALE: 1/8" = 1'-0"

2

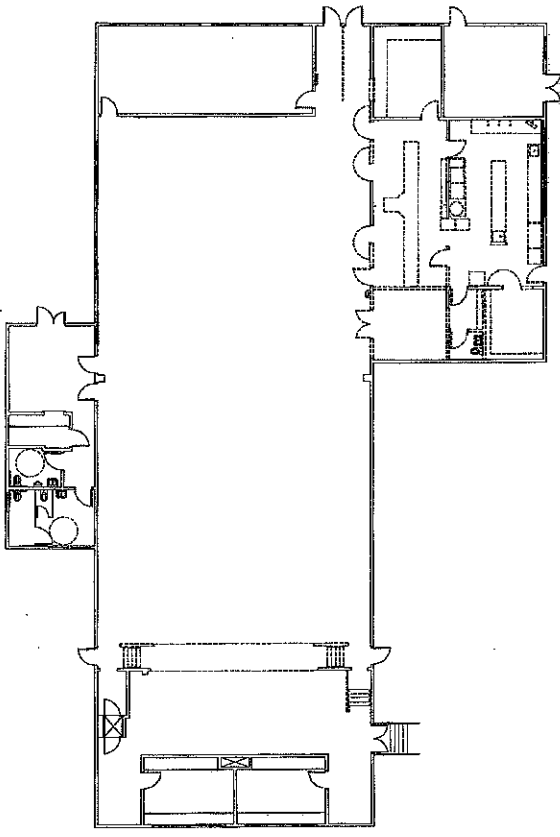

BUILDING H - AUDITORIUM/CAFETERIA/KITCHEN - DEMOLITION FLOOR PLAN

SCALE: 1/8" = 1'-0"

1

KEY PLAN

**WFC**  
**Architects, Inc.**  
 ARCHITECTS  
 SOVIETEN CALIFORNIA  
 8137 Woodbury Avenue, Suite 118  
 Culver City, CA 90230  
 Tel: 310/441-2000  
 Fax: 310/441-2000

**FRANKLIN ELEMENTARY SCHOOL  
 MODERNIZATION**  
 PASADENA UNIFIED SCHOOL DISTRICT  
 593 WEST WOODBURY ROAD, ALTADENA, CA 91001



CONSULTANT

NO.	DATE	DESCRIPTION	BY	CHECKED
1				
2				
3				
4				
5				
6				
7				
8				
9				
10				
11				
12				
13				
14				
15				
16				
17				
18				
19				
20				
21				
22				
23				
24				
25				
26				
27				
28				
29				
30				
31				
32				
33				
34				
35				
36				
37				
38				
39				
40				
41				
42				
43				
44				
45				
46				
47				
48				
49				
50				
51				
52				
53				
54				
55				
56				
57				
58				
59				
60				
61				
62				
63				
64				
65				
66				
67				
68				
69				
70				
71				
72				
73				
74				
75				
76				
77				
78				
79				
80				
81				
82				
83				
84				
85				
86				
87				
88				
89				
90				
91				
92				
93				
94				
95				
96				
97				
98				
99				
100				

PROJECT NUMBER: AH2.1





(D)

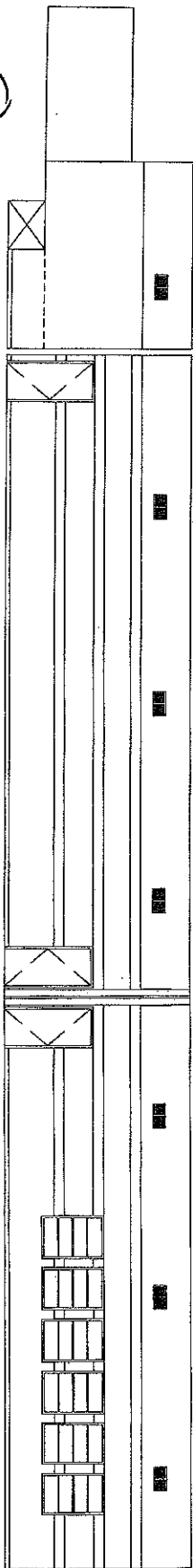

(A)

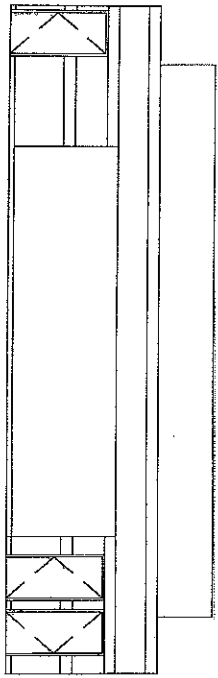

(B)

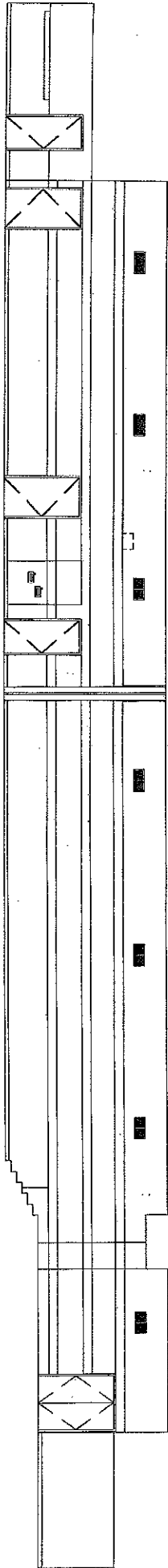

(C)

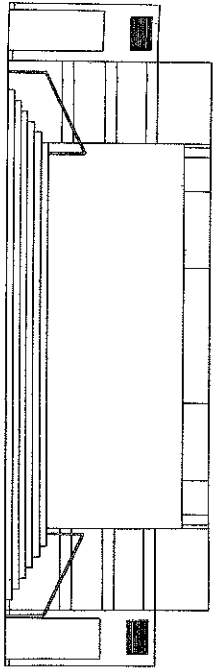

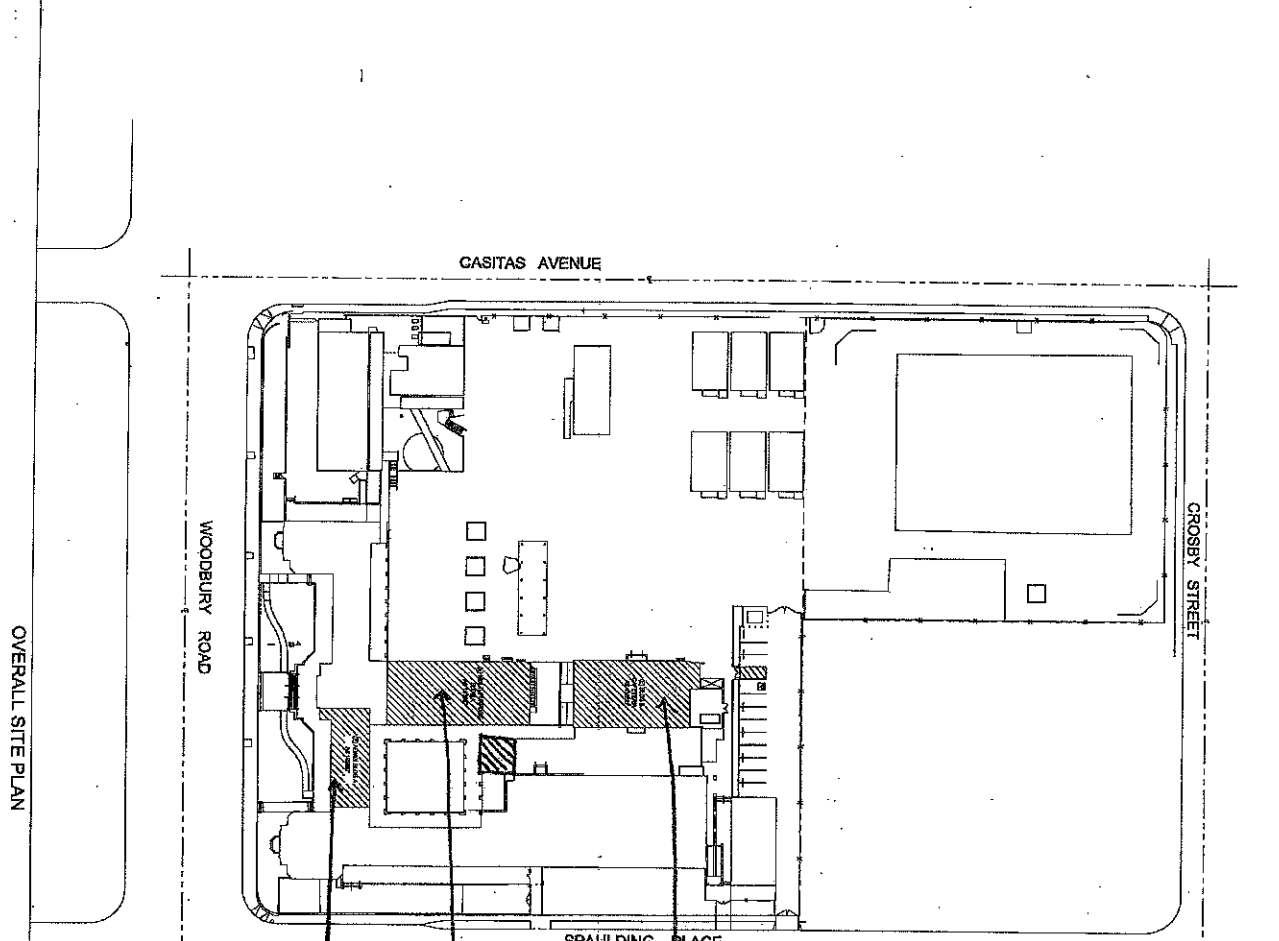

OVERALL SITE PLAN

SCALE: 1" = 30'-0"



PARKING DATA

PARKING AREA	TOTAL TYPE		TOTAL
	STANDARD	ACCESSIBLE	
STREET PARKING	41	1	42

**LEGEND**

- EXISTING IMPROVEMENTS
- PROPOSED IMPROVEMENTS
- EXISTING BUILDING
- PROPOSED DRIVEWAY
- PROPOSED SIDEWALK
- PROPOSED CURB
- PROPOSED DRIVE
- PROPOSED DRIVEWAY
- PROPOSED SIDEWALK
- PROPOSED CURB
- PROPOSED DRIVE

Occupancy Group: A2  
 Occupancy Type: V/A  
 Sprinklered: YES

Occupancy Group: E/B  
 Occupancy Type: V/B  
 Sprinklered: YES

Occupancy Group: A2  
 Occupancy Type: V/B  
 Billions Area: 33.95 SQ FT  
 Sprinklered: NO

**GENERAL NOTES**

1. ALL WORK SHALL BE IN ACCORDANCE WITH THE LATEST EDITIONS OF THE CALIFORNIA BUILDING CODE, THE CALIFORNIA FIRE CODE, AND THE CALIFORNIA ELECTRICAL CODE.
2. ALL WORK SHALL BE IN ACCORDANCE WITH THE LATEST EDITIONS OF THE CALIFORNIA BUILDING CODE, THE CALIFORNIA FIRE CODE, AND THE CALIFORNIA ELECTRICAL CODE.
3. ALL WORK SHALL BE IN ACCORDANCE WITH THE LATEST EDITIONS OF THE CALIFORNIA BUILDING CODE, THE CALIFORNIA FIRE CODE, AND THE CALIFORNIA ELECTRICAL CODE.
4. ALL WORK SHALL BE IN ACCORDANCE WITH THE LATEST EDITIONS OF THE CALIFORNIA BUILDING CODE, THE CALIFORNIA FIRE CODE, AND THE CALIFORNIA ELECTRICAL CODE.
5. ALL WORK SHALL BE IN ACCORDANCE WITH THE LATEST EDITIONS OF THE CALIFORNIA BUILDING CODE, THE CALIFORNIA FIRE CODE, AND THE CALIFORNIA ELECTRICAL CODE.
6. ALL WORK SHALL BE IN ACCORDANCE WITH THE LATEST EDITIONS OF THE CALIFORNIA BUILDING CODE, THE CALIFORNIA FIRE CODE, AND THE CALIFORNIA ELECTRICAL CODE.
7. ALL WORK SHALL BE IN ACCORDANCE WITH THE LATEST EDITIONS OF THE CALIFORNIA BUILDING CODE, THE CALIFORNIA FIRE CODE, AND THE CALIFORNIA ELECTRICAL CODE.
8. ALL WORK SHALL BE IN ACCORDANCE WITH THE LATEST EDITIONS OF THE CALIFORNIA BUILDING CODE, THE CALIFORNIA FIRE CODE, AND THE CALIFORNIA ELECTRICAL CODE.
9. ALL WORK SHALL BE IN ACCORDANCE WITH THE LATEST EDITIONS OF THE CALIFORNIA BUILDING CODE, THE CALIFORNIA FIRE CODE, AND THE CALIFORNIA ELECTRICAL CODE.
10. ALL WORK SHALL BE IN ACCORDANCE WITH THE LATEST EDITIONS OF THE CALIFORNIA BUILDING CODE, THE CALIFORNIA FIRE CODE, AND THE CALIFORNIA ELECTRICAL CODE.

**JACKSON ELEMENTARY SCHOOL  
 MODERNIZATION**  
 PASADENA UNIFIED SCHOOL DISTRICT  
 593 WEST WOODBURY ROAD, ALTADENA, CA 91001

**WFC**  
 Architects, Inc.  
 4141 North Hollywood Blvd., Suite 100  
 North Hollywood, CA 91602  
 Phone: (818) 706-7000  
 Fax: (818) 706-7000  
 Website: www.wfc.com

**OVERALL SITE PLAN**

DATE: 08/11/2010  
 DRAWN BY: [Name]  
 CHECKED BY: [Name]  
 PROJECT NUMBER: 08-000

DATE: 08/11/2010  
 DRAWN BY: [Name]  
 CHECKED BY: [Name]  
 PROJECT NUMBER: 08-000

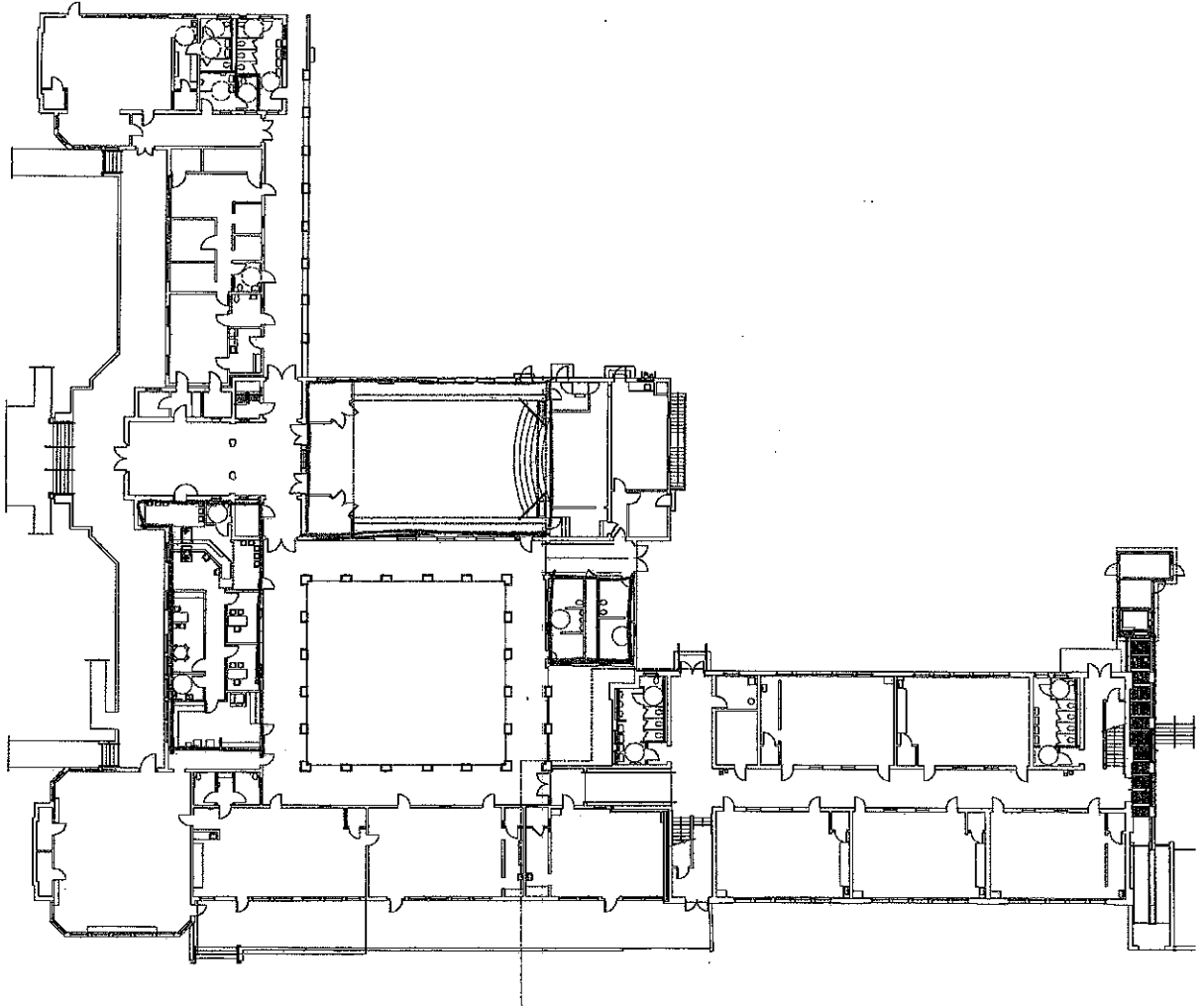

JACKSON BS  
BURS A





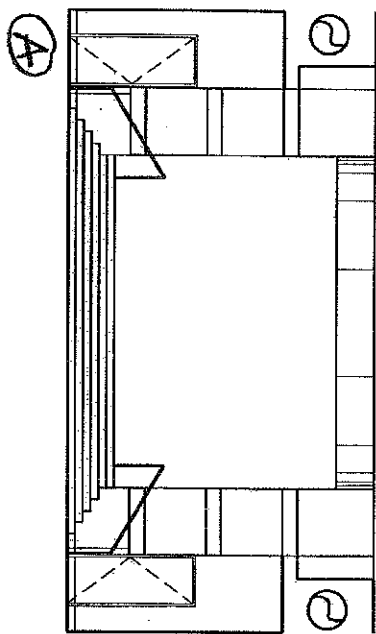
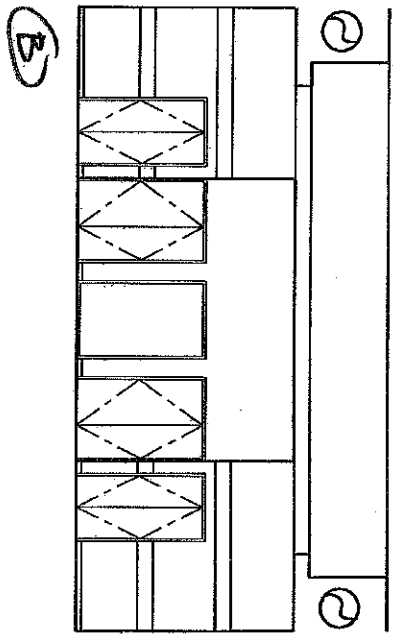





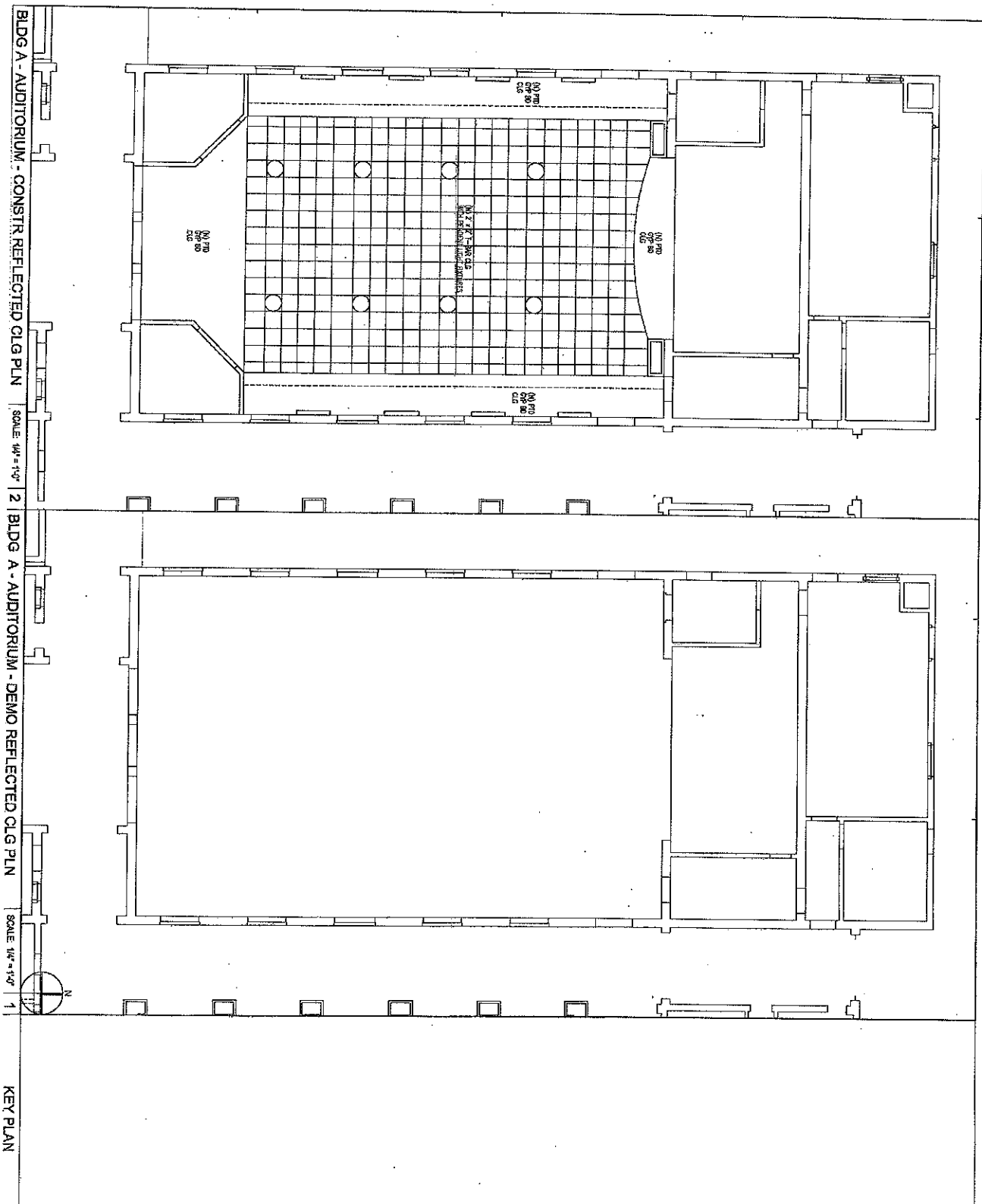

KEY PLAN

PROGRAM NUMBER AA3.2

NO	DATE	BY	DISPOSITION	REVISION

CONTRACTOR



**JACKSON ELEMENTARY SCHOOL  
MODERNIZATION**  
PASADENA UNIFIED SCHOOL DISTRICT  
593 WEST WOODBURY ROAD, ALTADENA, CA 91001

**W.C. Architects, Inc.**  
NORTHERN CALIFORNIA ARCHITECTS  
8142 Madison Avenue, Suite 101  
Alhambra, California 91802  
Tel: 626/282-8899  
Fax: 626/282-8898

BLDG B - CAFETERIA - CONSTRUCTION FLOOR PLAN

SCALE: 1/4" = 1'-0"

2

BLDG B - CAFETERIA - DEMOLITION FLOOR PLAN

SCALE: 1/4" = 1'-0"

1

KEY PLAN

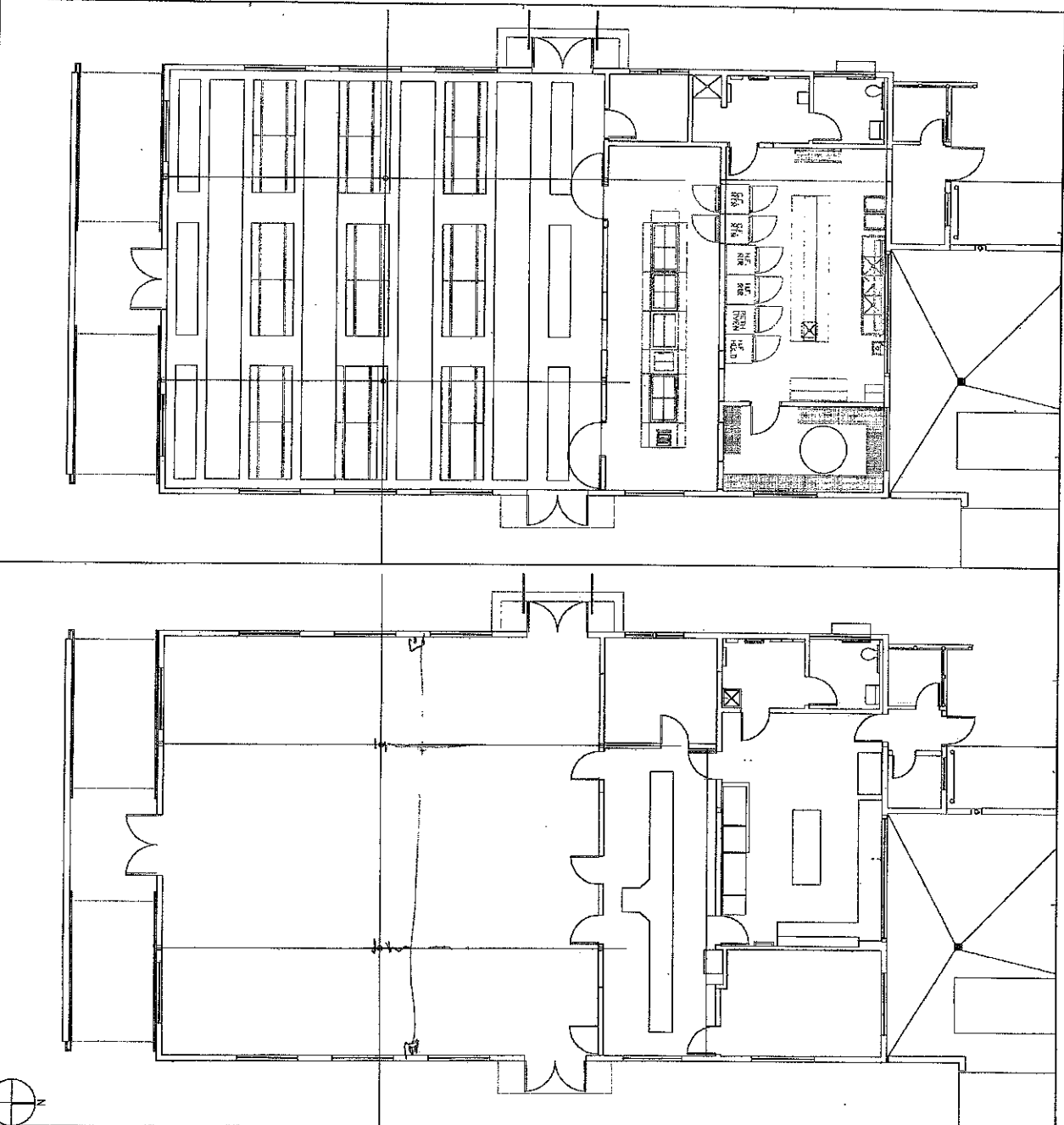

REVISIONS

NO.	DATE	BY	DESCRIPTION

DATE: 02/04/10  
 PROJECT NUMBER: 081000  
 DRAWING TITLE: CAFETERIA 'B' DEMO/CONSTR FLOOR PLANS  
 DRAWN BY: [Signature]  
 CHECKED BY: [Signature]  
 PROJECT MANAGER: [Signature]

**JACKSON ELEMENTARY SCHOOL  
 MODERNIZATION**  
 PASADENA UNIFIED SCHOOL DISTRICT  
 593 WEST WOODBURY ROAD, ALTADENA, CA 91001

**WLC**  
 Architects, Inc.  
 300 WESTERN AVENUE, SUITE 100  
 PASADENA, CALIFORNIA 91101  
 Phone: 626-792-1100  
 Fax: 626-792-1101  
 www.wlcarchitects.com

BLDG B - CAFETERIA- CONSTR REFLECTED QLG PLAN

SCALE: 1/4" = 1'-0"

2

BLDG B - CAFETERIA - DEMO REFLECTED QLG PLAN

SCALE: 1/4" = 1'-0"

1

KEY PLAN

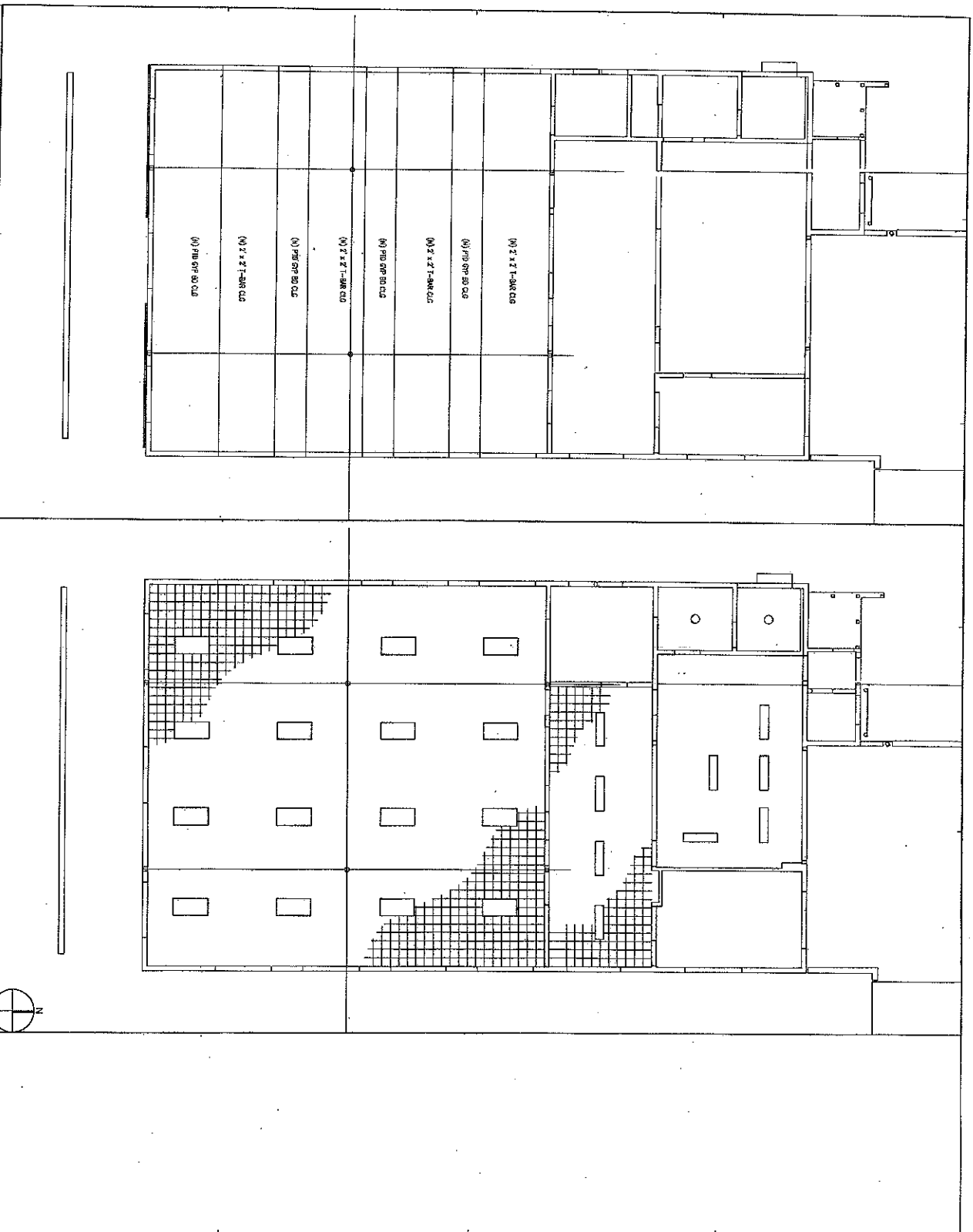

DRAWING NUMBER AB3.1

NO.	DATE	BY	DESCRIPTION

CONTRACT NO. \_\_\_\_\_  
 PROJECT NUMBER: 010000

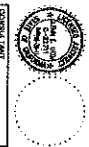

**JACKSON ELEMENTARY SCHOOL  
 MODERNIZATION**  
 PASADENA UNIFIED SCHOOL DISTRICT  
 593 WEST WOODBURY ROAD, ALTADENA, CA 91001

**WFC**  
 Architects, Inc.  
 SOUTHERN CALIFORNIA  
 1110 Wilshire Avenue, Suite 102  
 Altadena, California  
 California 714/250-1272  
 FAX 909/250-2002  
 INC 909/250-2002